

Product Description

The LR24 is a revolutionary architectural lay-in designed for applications that require high ambient light levels, including offices, schools, and hospitals. It utilizes Cree LED Lighting technology that generates white light with LEDs in a new way and is the first to combine high efficacy, beautiful color and affordability.

The use of this technology releases the design constraints of traditional lay-ins and enables a fresh approach to the architectural appearance of the light. It also allows an optimal distribution of light that delivers high illuminance levels to horizontal surfaces balanced with an ideal amount of light to vertical surfaces resulting in an effective, attractive, and comfortable environment.

Delivered light output is set to provide the ideal amount of light with the lowest possible energy consumption for standard ceiling heights.

Performance Summary

The LR24 is designed to deliver an optimal amount of light with typical luminaire spacing.

- Utilizes Cree TrueWhite™ technology
- CRI = 90
- 3500K
- Dimmable to 5% with 0-10V DC control
- 3200 lumens – 40FC maintained with typical 8'x8' spacing and ceiling*
- Nominal input power = 44 Watts
- Three Year Warranty

*Note: Light levels based on common room configurations will vary based upon actual conditions

Ordering Information

LR24-32SKA35 - 120V-277V, 3200 lumens, 3500K

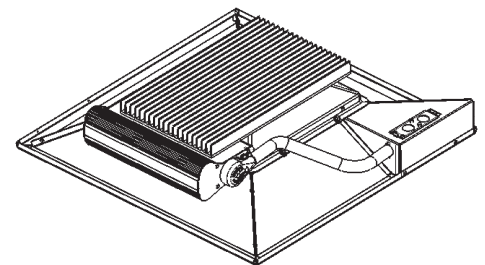
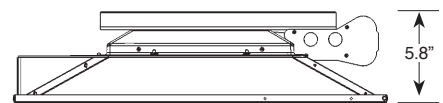
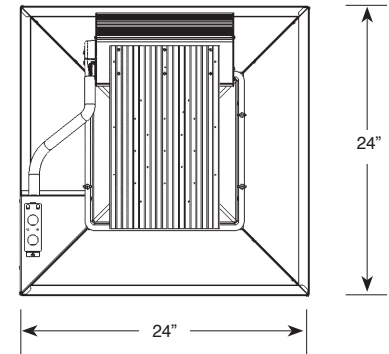

Product Information

Cree TrueWhite™ Technology

- A better way to generate white light that utilizes a patented mixture of unsaturated yellow and saturated red LEDs.
- Tuned to optimal color point before shipment.
- Color management system maintains color consistency over time and temperature.
- Designed to last 50,000 hours and maintain at least 70% of initial lumen output.

Construction

- Cold rolled steel lower reflector for installation in nominal 2' x 2' ceiling openings.
- Field replaceable light engine integrates LEDs, driver, power supply, thermal management, and optical mixing components. Access to light engine from adjoining ceiling tiles.
- Integrated thermal management system conducts heat away from LEDs and transfers it to the surrounding environment. Designed to keep LEDs below specified maximum temperatures in typical commercial installations.
- Height = 5.8"

Optical System

- Proprietary optical system utilizes a unique combination of reflective and refractive optical components to achieve a uniform, comfortable appearance. Pixelation and direct view of uncomfortable LEDs is eliminated.
- Lower reflector finished with a textured high reflectance white polyester powder coating to create a comfortable visual transition from the diffuser to the ceiling plane.
- Mechanical shielding of diffuser delivers a subtle glowing appearance at high angles for visual integration with the ceiling plane.
- Distribution of light balances the delivery of high light levels to horizontal surfaces with an ideal amount of light to vertical surfaces.

Electrical System

- Integral, high efficiency driver and power supply.
- Nominal Power Factor = 0.9
- Input voltage = 120V - 277V, 50/60Hz
- Dimmable to 5% with 0 to 10V DC control protocol

Regulatory and Voluntary Programs

- Tested and certified to UL standards

Photometry

LR24-32SKA35 – Based on ITL Test 61450

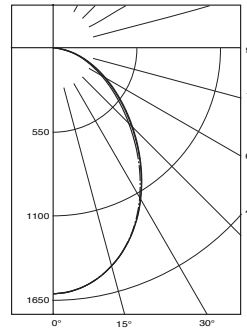

Intensity (Candlepower) Summary

ANGLE	CP°	CP45°
0°	1600	1600
5°	1582	1584
15°	1467	1469
25°	1258	1263
35°	981	996
45°	695	721
55°	459	482
65°	276	294
75°	131	142
85°	2	5
90°	0	0

Zonal Lumen Summary

ZONE	LUMENS	%LAMP	%FIX
0° - 30°	1145	53.5	53.5
0° - 40°	1767	76.9	76.9
0° - 60°	2750	98.8	98.8
0° - 90°	3200	100.00	100.00